

# MOISTURE BALANCES - CAL SERIES

## 0.001g to 180g

**CONTECH** CAL series Moisture balances employ most modern technology combined with best computing capabilities to produce a very reliable, accurate and fast determination of moisture content in a sample, using weight loss on drying method. It incorporates a 5" touch screen display to easily enter the testing and other parameters.

### Features :

- 3 types of Testing Methods:- Manual, Time Programmable, Automatic.
- Drying using infrared halogen lamp for faster moisture determination.
- Uniform heating due to the reflecting sample chamber.
- Moisture measurement Unit - % Moisture on wet base  
% Moisture on dry base  
% dry to wet weight ratio  
% wet to dry weight ratio  
% Weight loss in grams
- 5" Touch screen graphic display.
- Real time graph of moisture loss on the display.
- 10 programmable drying methods.
- Storage of 100 test results in memory.
- Admin and ten users for GLP reports.
- Bidirectional RS 232 interface to interface with computers and printers.
- Printing & Display of test results on the completion of the test.
- Programmable periodic printing of moisture % while testing.

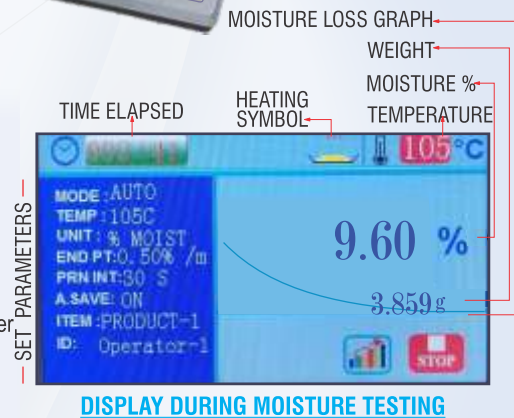
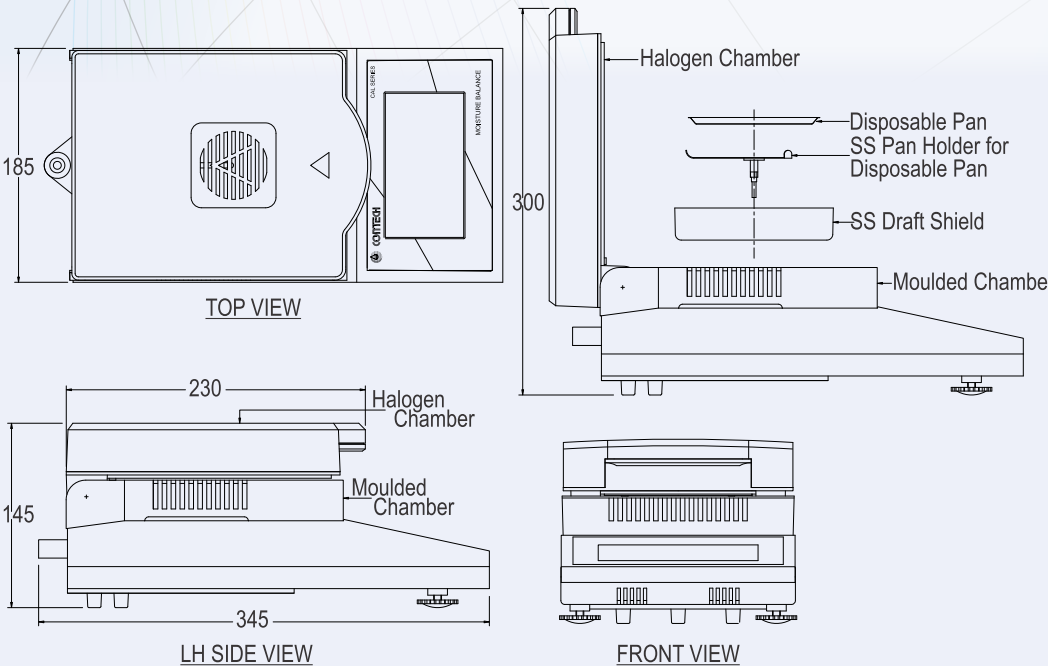

DISPLAY DURING MOISTURE TESTING



DISPLAY OF TEST RESULTS

Thermal printer

### Specifications :

#### Moisture Content :

- Accuracy : 0.05% for sample above 5g  
0.1% for sample below 5g
- Resolution : 0.01%
- Temp. range : Ambient to 200 deg C in 1 deg increment
- Timer setting : 3min. to 120min. in 1min. increment.
- End point setting in auto mode : 0.01% per minute to 5% per minute
- Print interval selection : 10, 20, 30, 60, 120 seconds
- Taring Range : Up to full capacity
- Power Req : 230V±10%V AC, 50/60Hz, 550 Watt
- Operating Temperature : 15~50 deg C
- Dimension (mm) : 345 (L) x 185 (W) x 145 (H) when cover is closed.  
: 345 (L) x 185 (W) x 300 (H) when cover is open.

### Optional Accessories :

- Aluminum sample pan
- Certified standard weights
- Certified temperature kit
- RS 232 to USB convertor
- 21CFR Part 11 / GLP compliant
- Thermal printer / Dot matrix printer

Models	CAL-63 (M)	CAL-133(M)	CAL-183(M)
Capacity	60g	130g	180g
Readability	0.001g	0.001g	0.001g
Pan Size(mm)	100	100	100

All Specifications and designs are subject to change for improvement.

FACTORY / NABL LAB