

High Resolution loadcell based 1 mg accuracy Balance

0.001g to 50g

Features :

- ◆ Incorporate high quality loadcells.
- ◆ Compact, Light weight and portable.
- ◆ Inbuilt battery charger.
- ◆ Auto power off function.
- ◆ Multiple weighing units, gram & carat.
- ◆ RS-232 bi directional interface.
- ◆ Power saving mode.
- ◆ Overload and shockload protection.
- ◆ Bright Red LED Display/LCD Display with white backlite.
- ◆ High bright green LED Display (Optional).
- ◆ Battery Backup (Optional).
- ◆ Additional Display (Optional).
- ◆ Breeze shield.

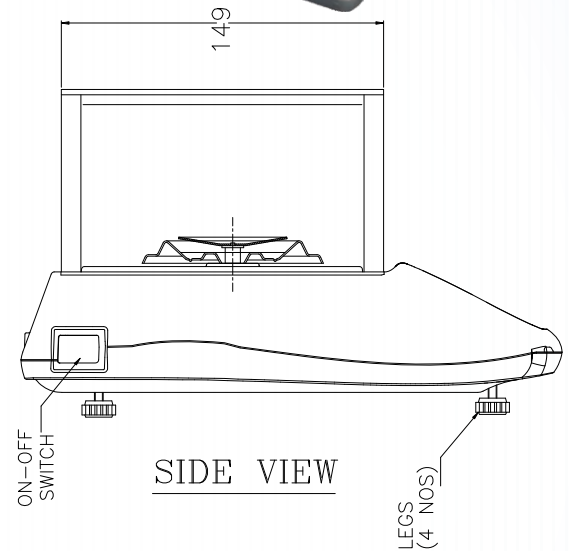
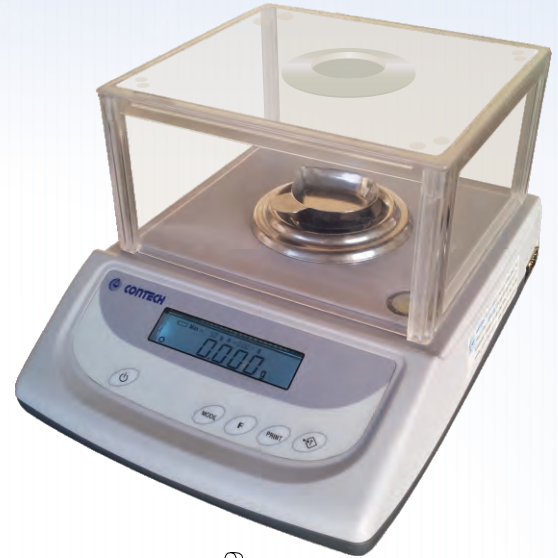

Specifications :

Models	CTL-20	CTL-50
Capacity	20g	50g
Readability	0.001g	0.001g
Repeatability (±)	0.001g	0.001g
Linearity (±)	0.001g	0.002g
Pan Size (mm ø)	50	50

Taring Range : Up to full capacity
 Response time : 3-5 secs
 Power Req : 90-250V, 50/60Hz, 10 Watt
 Operating Temperature : 10 to 45 deg C

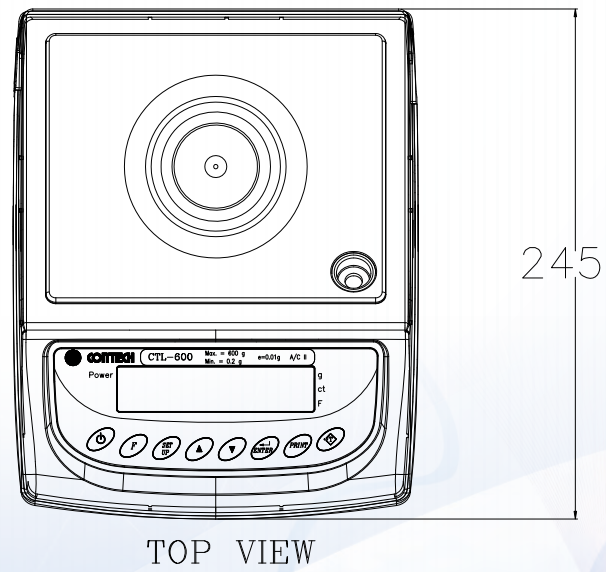
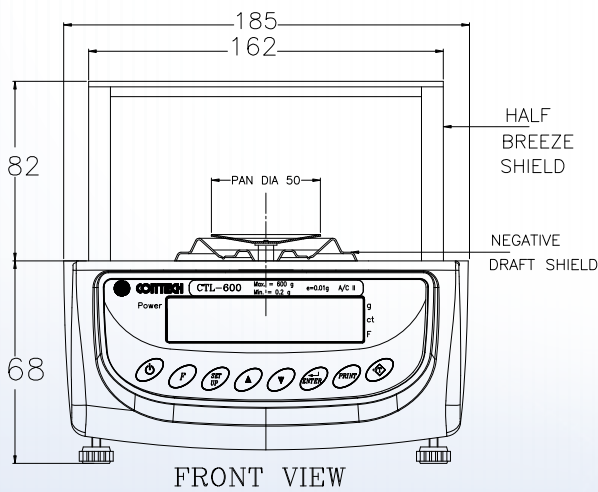

All Specifications and designs are subject to change for improvement.