

# CRANE SCALES

100g to 2ton

(0.5, 1 ton)

## STANDARD CRANE SCALES (CCS)

### Features :

- ♦ Rugged aluminum diecast enclosure.
- ♦ 25 mm height LED display
- ♦ Maximum safety overload 200%.
- ♦ Inbuilt sealed maintenance free re-chargeable battery and battery charger (Optional)
- ♦ RF keyboard, operating distance 20mtr. (optional)
- ♦ RS-232 Interface (Optional)
- ♦ Multiple print options with Sr. No, Date, Time & Weight in horizontal / vertical mode.
- ♦ Date & Time entry facility.
- ♦ Multiple weighing units.
- ♦ Storage of weights in memory upto 100 samples.
- ♦ Power saving by switching off the display.
- ♦ Automatic zero tracking.
- ♦ Software linearity correction.
- ♦ Display hold facility.
- ♦ Gross & Net Weight function.



### Common Specifications :

| MODELS      | CAPACITY | ACCURACY | NET WT.<br>(Kg) |
|-------------|----------|----------|-----------------|
| CCS-500K100 | 500Kg    | 100g     | 4.2             |
| CCS-1T200   | 1000Kg   | 200g     | 4.2             |

Taring Range : Up to full capacity

Response time : 5 seconds

Power Req : 90-250V, 50/60Hz, 10 Watt

Operating Temperature : 10 to 45 deg C

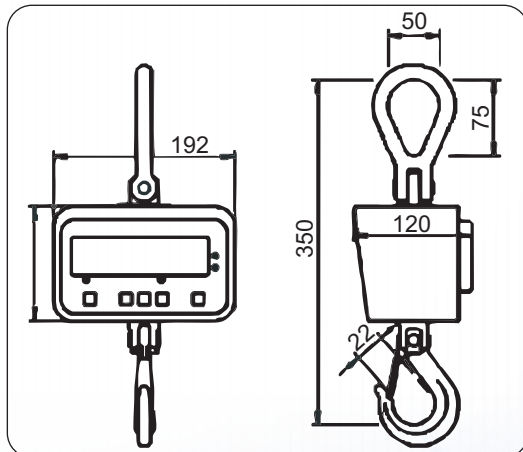

All Specifications and designs are subject to change for improvement.