

# SEMI MICRO BALANCES (CAI Series)

0.00001g to 60g

**CONTECH** Semi micro Balances incorporate advanced Electro Magnetic Force Compensation (EMFC) technology for offering unmatched accuracy and reliability, coupled with unique ADC circuit with inbuilt temperature compensation to offer a very high stability upto a resolution of 6 million counts. All adjustment parameters are programmable to take care of any minor mismatch of different sub assemblies & Balances are configured with these parameters.

## Standard Features

- Backlite LCD Display
- Motorized internal calibration. (Standard)
- Bi directional RS 232 interface
- GSM function
- Multiple Weighing Units
- Percentage Weighing
- Piece Counting
- Fill Mode
  - 1 set point - Indication when sample weight exceeds the set limit.
  - 2 set points - Indication when the sample weight is between the lower & upper limits.
- Accumulation
  - Storage of maximum 200 samples.
- Multiple Printing Mode
- External Calibration
- Response Time:
  - User selectable - Slow / Normal /Fast.
- Stability Band Width
- Auto Zero Tracking
- Return to Zero Tracking
  - Variable: 0,1,2,3,4
- Display Updation
  - Speed setting : Fast / Normal.

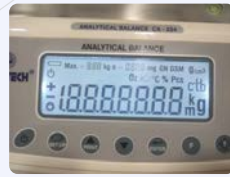
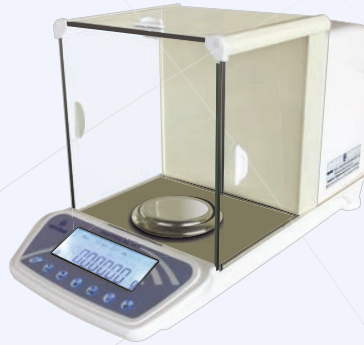

Customized, large, attractive LCD with Multiparameter display illuminated by white backlight



5" touch screen graphic display panel with keys configured for various applications

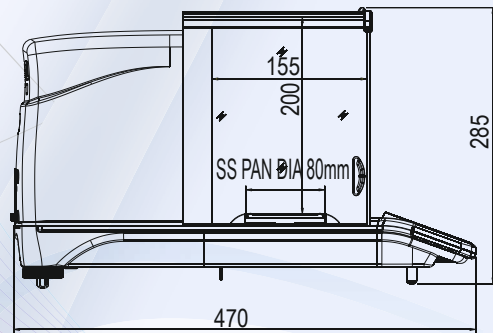
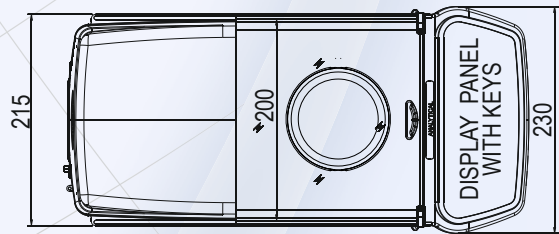

## Optional Features (Extra charges applicable)

- ◆ 5" Touch screen graphic display.
- ◆ 21CFR Part 11 compliance (Optional only with TFT display)
- ◆ RS 232 to USB interface converter.
- ◆ GLP compliance/RTC.
- ◆ Density determination kit.
- ◆ Weigh below hook for density determination.
- ◆ Yarn count with temperature compensation.
- ◆ Denier measurement for silk & synthetic yarn.
- ◆ Anti vibration table.
- ◆ Standard weights / weight box.

## Semi Micro Balances with motorized internal calibration

Models	CAI-35	CAI-65
Capacity	30g	60g
Readability	0.00001g	0.00001g
Repeatability (±)	0.03mg	0.05mg
Linearity (±)	0.05mg	0.05mg
Pan Size(mm)	80	80

## Specifications :

- Taring Range : Up to full capacity
  - Response time : 3-5 seconds
  - Power Req : 90-250V, 50/60Hz, 10 Watt
  - Operating Temperature : 10~45 deg C
  - Dimension (mm) : 470(L) x 230(W) x 285(H)
- All Specifications and designs are subject to change for improvement.



301, Punit Indl. Premises, Turbhe Naka, Navi Mumbai - 400 705.  
 Tel. : +91 22 6139 3000 (100 lines)  
 E-mail : sales@contechindia.in  
 Website : www.contechindia.com



Plot No. EL-221 TTC Indl. Area, MIDC (Electronic Zone),  
 Mhape, Navi Mumbai - 400 710.

## Impeccable Credentials

