

HIGH PRECISION BALANCES (CAH Series)

0.001g to 1000g

CONTECH High Precision Balances incorporate advanced Electro Magnetic Force Compensation (EMFC) technology for offering unmatched accuracy and reliability, coupled with unique ADC circuit with inbuilt temperature compensation to offer a very high stability upto a resolution of 6 million counts. All adjustment parameters are programmable to take care of any minor mismatch of different sub assemblies & Balances are configured with these parameters.

Standard Features

- Backlite LCD Display
- Bi directional RS 232 interface
- GSM function
- Multiple Weighing Units
- Percentage Weighing
- Piece Counting
- Fill Mode
- 1 set point - Indication when sample weight exceeds the set limit.
- 2 set points - Indication when the sample weight is between the lower & upper limits.

Accumulation

Storage of maximum 200 samples.

Multiple Printing Mode

External Calibration

Response Time:

User selectable - Slow / Normal /Fast.

Stability Band Width

Auto Zero Tracking

User selectable 0,1,2,3

Return to Zero Tracking

Variable: 0,1,2,3,4

Display Updation

Speed setting : Fast / Normal.

Removable breeze shield with 2 side and top glass sliding door

Optional Features (Extra charges applicable)

- 5" Touch screen graphic display.
- 21CFR Part 11 compliance (Optional only with TFT display)
- Motorized internal calibration.
- RS 232 to USB interface converter.
- GLP compliance/RTC.
- Density determination kit.
- Weigh below hook for density determination.
- Yarn count with temperature compensation.
- Denier measurement for silk & synthetic yarn.
- Standard weights / weight box.



Models with motorized internal calibration

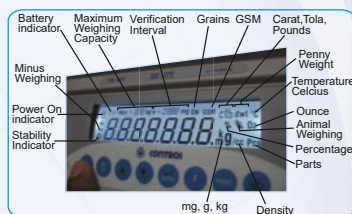

Customized, attractive LCD display

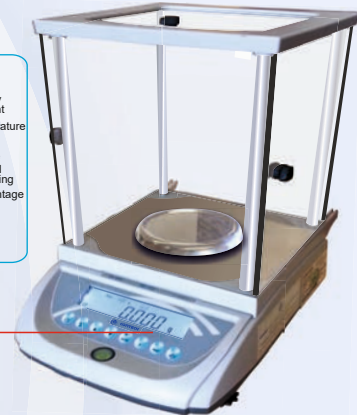

Standard Models without motorized internal calibration

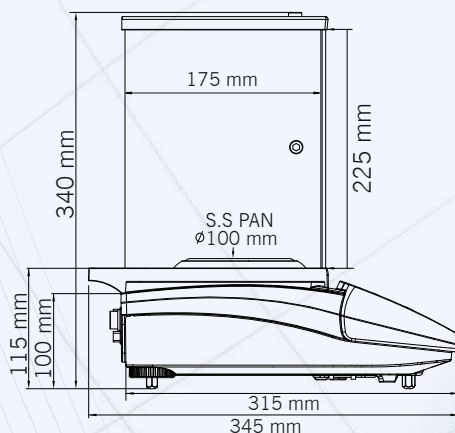

SIDE VIEW

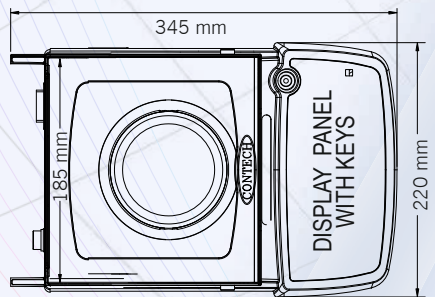
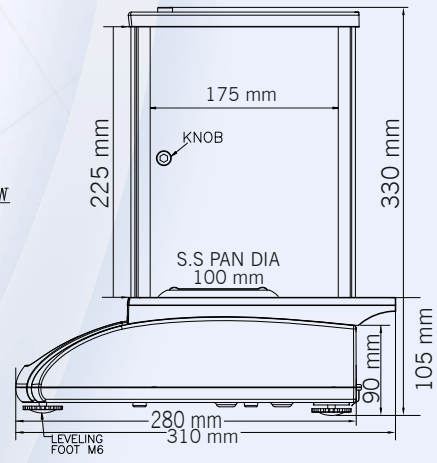

TOP VIEW

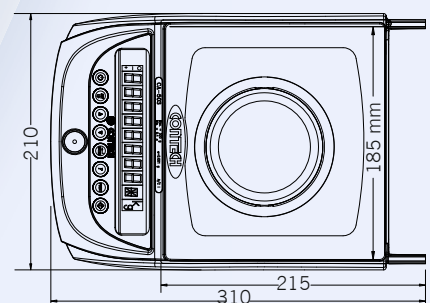

High Precision Balances without motorized internal calibration

Models	CAH-53	CAH-123	CAH-223	CAH-323	CAH-413	CAH-503
Capacity	50g	120g	220g	320g	410g	500g
Readability	0.001g	0.001g	0.001g	0.001g	0.001g	0.001g
Repeatability(±)	0.001g	0.001g	0.001g	0.001g	0.001g	0.002g
Linearity(±)	0.001g	0.001g	0.002g	0.002g	0.002g	0.002g
Pan Size(mm)	100	100	100	100	100	100

High Precision Balances without motorized internal calibration

Models	CAH-603	CAH-803	CAH-1003
Capacity	600g	800g	1000g
Readability	0.001g	0.001g	0.001g
Repeatability(±)	0.002g	0.002g	0.002g
Linearity(±)	0.003g	0.004g	0.004g
Pan Size(mm)	125	125	125



Models with touch screen display



5" touch screen graphic display panel with keys configured for various applications

Specifications :

- Taring Range : Up to full capacity
- Response time : 2-3 seconds
- Power Req : 90-250V, 50/60Hz, 10 Watt
- Operating Temperature : 10~45 deg C

Dimension (mm):

- Standard Model - 310(L) x 210(W) x 330(H)
- Internal Calibration/Touch Screen model - 345(L) x 220(W) x 340(H)

All Specifications and designs are subject to change for improvement.



301, Punit Indl. Premises, Turbhe Naka, Navi Mumbai - 400 705.
 Tel. : +91 22 6139 3000 (100 lines)
 E-mail : sales@contechindia.in
 Website : www.contechindia.com

Impeccable Credentials

FACTORY / NABL LAB



Plot No. EL-221 TTC Indl. Area, MIDC (Electronic Zone),
 Mhape, Navi Mumbai - 400 710.

