

# CRANE SCALES

5kg to 30ton

## CRANE SCALES with Wireless Indicator

### Features :

- ♦ Wireless transmission maximum operating distance between the Scale and Indicator is 50 mtr.
- ♦ All specifications are same as standard crane scales (CCS) except there is no display on the scale and there is no RF keyboard.
- ♦ Power indication LED on the scale.
- ♦ Battery & charger for the loadcell & transmitter inside the scale.
- ♦ Weight display on the desktop indicator along with controls.
- ♦ RS-232 interface in the indicator (Optional).
- ♦ Indicator with optional battery backup.
- ♦ Date & time entry facility.
- ♦ Storage of weights in memory upto 100 samples.
- ♦ Display hold facility.



30T

### Common Specifications :

| MODELS     | CAPACITY | ACCURACY | DIMENSION |     |     |    | NET WT. |
|------------|----------|----------|-----------|-----|-----|----|---------|
|            |          |          | H         | A   | B   | C  |         |
| CCS-30T10K | 30 ton   | 10Kg     | 1072      | 140 | 145 | 80 | 143     |

Taring Range : Up to full capacity

Response time : 5 seconds

Power Req : 90-250V, 50/60Hz, 10 Watt

Operating Temperature : 10 to 45 deg C

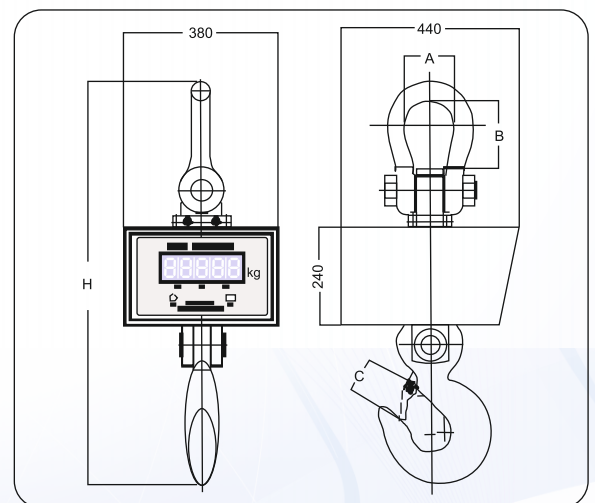

All Specifications and designs are subject to change for improvement.



301, Punit Indl. Premises, Turbhe Naka, Navi Mumbai - 400 705.

Tel. : +91 22 6139 3000 (100 lines)

E-mail : sales@contechindia.in

Website : www.contechindia.com



Plot No. EL-221 TTC Indl. Area, MIDC (Electronic Zone),  
Mhape, Navi Mumbai - 400 710.

### Impeccable Credentials

