

# CRANE SCALES

100g to 1 ton

(0.5, 1 ton)

## CRANE SCALES with Wireless Indicator

### Features :

- ♦ Wireless transmission maximum operating distance between the Scale and Indicator is 50 mtr.
- ♦ All specifications are same as standard crane scales (CCS) except there is no display on the scale and there is no RF keyboard.
- ♦ Power indication LED on the scale.
- ♦ Battery & charger for the loadcell & transmitter inside the scale.
- ♦ Weight display on the desktop indicator along with controls.
- ♦ RS-232 interface in the indicator (Optional).
- ♦ Indicator with optional battery backup.
- ♦ Date & time entry facility.
- ♦ Storage of weights in memory upto 100 samples.
- ♦ Display hold facility.



### Common Specifications :

MODELS	CAPACITY	ACCURACY	NET WT. (Kg)
CCS-500K100	500Kg	100g	4.2
CCS-1T200	1000Kg	200g	4.2

Taring Range : Up to full capacity

Response time : 5 seconds

Power Req : 90-250V, 50/60Hz, 10 Watt

Operating Temperature : 10 to 45 deg C

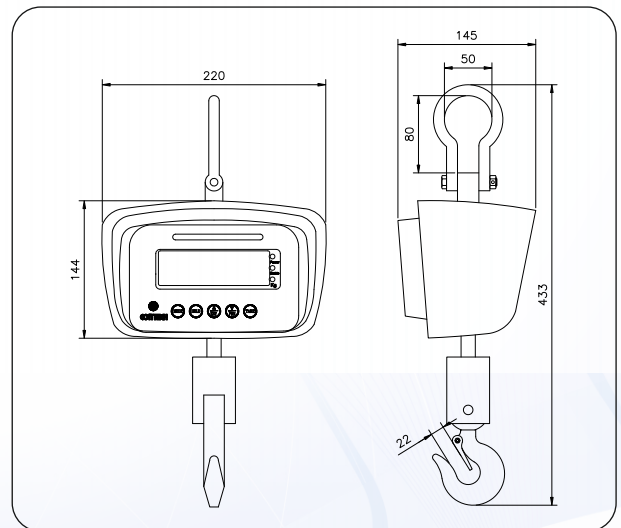

301, Punit Indl. Premises, Turbhe Naka, Navi Mumbai - 400 705.

Tel. : +91 22 6139 3000 (100 lines)

E-mail : sales@contechindia.in

Website : www.contechindia.com



Plot No. EL-221 TTC Indl. Area, MIDC (Electronic Zone), Mhape, Navi Mumbai - 400 710.

### Impeccable Credentials

