

CRANE SCALES

5kg to 20ton

CRANE SCALES with Wireless Indicator

Features :

- ♦ Wireless transmission maximum operating distance between the Scale and Indicator is 50 mtr.
- ♦ All specifications are same as standard crane scales (CCS) except there is no display on the scale and there is no RF keyboard.
- ♦ Power indication LED on the scale.
- ♦ Battery & charger for the loadcell & transmitter inside the scale.
- ♦ Weight display on the desktop indicator along with controls.
- ♦ RS-232 interface in the indicator (Optional).
- ♦ Indicator with optional battery backup.
- ♦ Date & time entry facility.
- ♦ Storage of weights in memory upto 100 samples.
- ♦ Display hold facility.

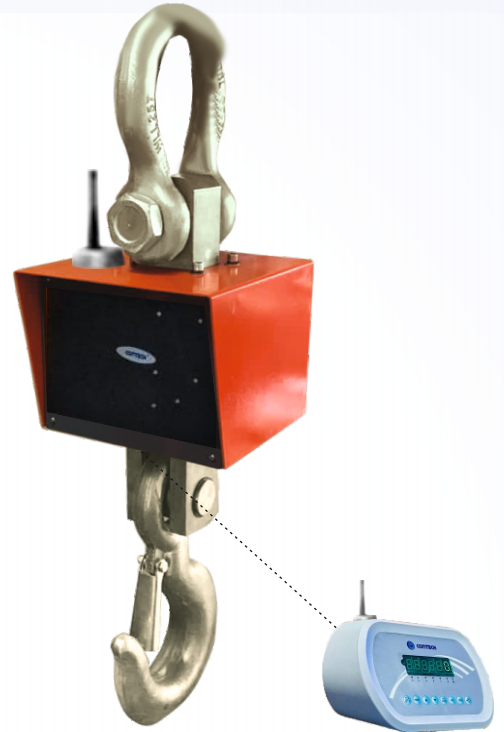

20T

Common Specifications :

MODELS	CAPACITY	ACCURACY	DIMENSION				NET WT.
			H	A	B	C	
CCS-20T5K	20 ton	5Kg	1058	130	230	65	100

Taring Range : Up to full capacity
 Response time : 5 seconds
 Power Req : 90-250V, 50/60Hz, 10 Watt
 Operating Temperature : 10 to 45 deg C

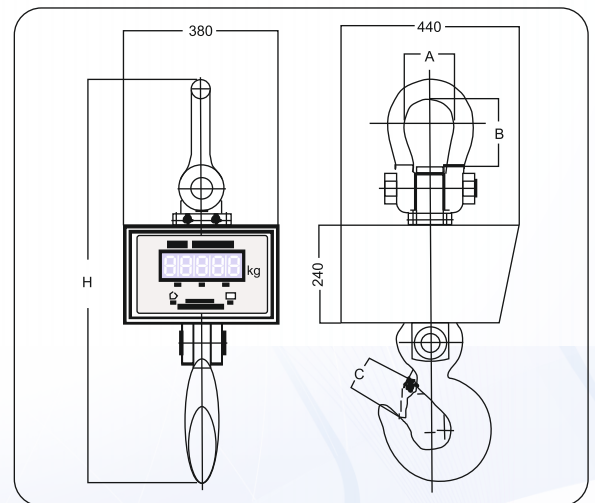

All Specifications and designs are subject to change for improvement.



301, Punit Indl. Premises, Turbhe Naka, Navi Mumbai - 400 705.
 Tel. : +91 22 6139 3000 (100 lines)
 E-mail : sales@contechindia.in
 Website : www.contechindia.com



Plot No. EL-221 TTC Indl. Area, MIDC (Electronic Zone),
 Mhape, Navi Mumbai - 400 710.

Impeccable Credentials

