

CRANE SCALES

500g to 10ton

(2, 3, 5, 10 ton)

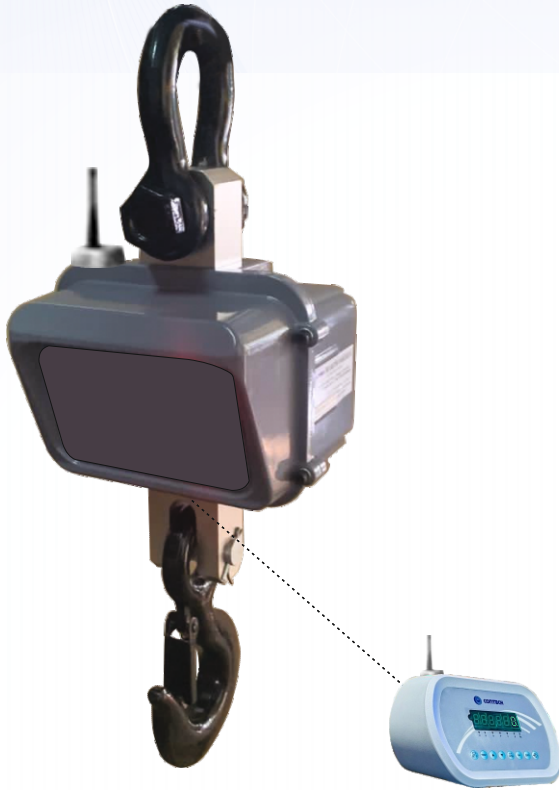

CRANE SCALES with Wireless Indicator

Features :

- ♦ Wireless transmission maximum operating distance between the Scale and Indicator is 50 mtr.
- ♦ All specifications are same as standard crane scales (CCS) except there is no display on the scale and there is no RF keyboard.
- ♦ Power indication LED on the scale.
- ♦ Battery & charger for the loadcell & transmitter inside the scale.
- ♦ Weight display on the desktop indicator along with controls.
- ♦ RS-232 interface in the indicator (Optional).
- ♦ Indicator with optional battery backup.
- ♦ Date & time entry facility.
- ♦ Storage of weights in memory upto 100 samples.
- ♦ Display hold facility.

Common Specifications :

MODELS	CAPACITY	ACCURACY	DIMENSION				NET WT. (Kg)
			H	A	B	C	
CCS-2T500	2 ton	500g	560	68	80	33	13
CCS-3T1K	3 ton	1Kg	560	68	80	33	13
CCS-5T2K	5 ton	2Kg	690	75	130	40	18
CCS-10T5K	10 ton	5Kg	775	90	115	45	29
CCS-15T5K	15 ton	5Kg	820	98	125	60	35

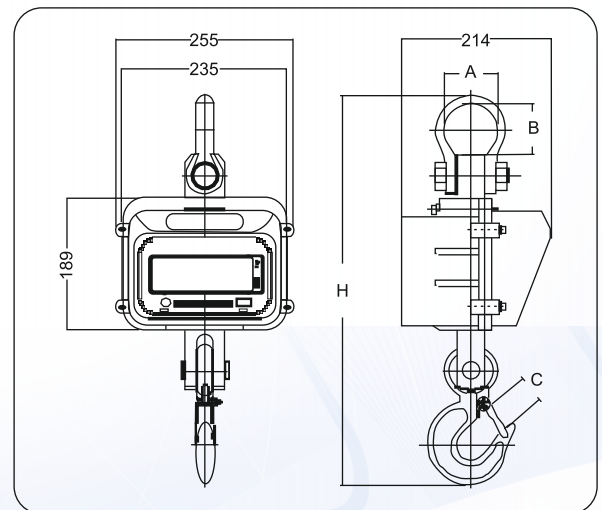

All Specifications and designs are subject to change for improvement.



301, Punit Indl. Premises, Turbhe Naka, Navi Mumbai - 400 705.
 Tel. : +91 22 6139 3000 (100 lines)
 E-mail : sales@contechindia.in
 Website : www.contechindia.com



Plot No. EL-221 TTC Indl. Area, MIDC (Electronic Zone),
 Mhape, Navi Mumbai - 400 710.

Impeccable Credentials

