

# CRANE SCALES with Heat Insulating Shield (CCS)

200g to 15ton

## Features :

- ◆ Heavy duty aluminum diecast enclosure.
- ◆ Special construction for high temperature shielding.
- ◆ Minimum distance for normal operation is 2 mtr from a heat radiation source at 1500° C.
- ◆ 25 mm height LED display
- ◆ Maximum safety overload 200%.
- ◆ Inbuilt sealed maintenance free re-chargeable battery and battery charger (Optional)
- ◆ Infrared remote keypad, operating distance 5 mtr (Optional)
- ◆ RS-232 Interface (Optional)
- ◆ Multiple print options with Sr. No, Date, Time & Weight in horizontal / vertical mode.
- ◆ Date & Time entry facility.
- ◆ Multiple weighing units.
- ◆ Storage of weights in memory upto 100 samples.
- ◆ Power saving by switching off the display.
- ◆ Automatic zero tracking.
- ◆ Software linearity correction.
- ◆ Display hold facility.
- ◆ Gross & Net Weight function.



(1, 2, 3, 5, 10, 15 ton)

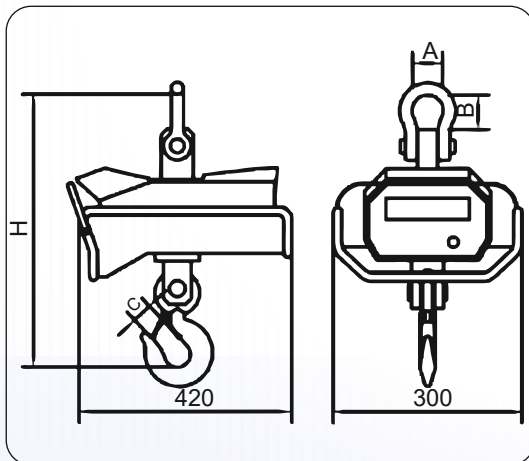

## Common Specifications :

MODELS	CAPACITY	ACCURACY	DIMENSION				NET WT. (Kg)
			H	A	B	C	
CCS-1T200	1 ton	200g	465	56	65	25	26
CCS-2T500	2 ton	500g	490	56	65	32	30
CCS-3T1K	3 ton	1Kg	570	72	90	36	36
CCS-5T2K	5 ton	2Kg	640	90	110	50	42
CCS-10T5K	10 ton	5Kg	920	140	230	60	77
CCS-15T5K	15 ton	5Kg	980	140	230	70	85

Taring Range : Up to full capacity

Response time : 5 seconds

Power Req : 90-250V, 50/60Hz, 10 Watt

Operating Temperature : 10 to 45 deg C

All Specifications and designs are subject to change for improvement.



**CONTECH<sup>®</sup>**  
Instruments Ltd.  
AN ISO 9001, 14001 & 45001 COMPANY

Where innovation never stops.....

301, Punit Indl. Premises, Turbhe Naka, Navi Mumbai - 400 705.

Tel. : +91 22 6139 3000 (100 lines)

E-mail : sales@contechindia.in

Website: www.contechindia.com

FACTORY / NABL LAB



Plot No. EL-221 TTC Indl. Area, MIDC (Electronic Zone),  
Mhape, Navi Mumbai - 400 710.