

Magnetic Stirrer with Heating CMS-02H

Features :

- ▶ Maximum temperature : 340°C
(Actual liquid temperature is lesser than the work plate temperature)
- ▶ Maximum Stirring Quantity : 5 litre water
- ▶ Backlite LCD with display of measuring parameters
- ▶ Display shows set & actual temperature & speed
- ▶ Provision for °C & °F temperature unit
- ▶ Inbuilt temperature sensor for the temperature setting & display
- ▶ Optional external temperature sensor for setting & measurement of liquid temperature with external control indication on display
- ▶ Inbuilt temperature safety cut off
- ▶ Temperature resolution : 1°C
- ▶ Temp. Setting Increment : 1°C
- ▶ Temperature control accuracy of work plate : $\pm 5^\circ\text{C}$
- ▶ Temperature control accuracy with external temperature probe : $\pm 1^\circ\text{C}$
- ▶ Maximum Stirring Speed : 1500rpm
- ▶ Speed Resolution : 1rpm
- ▶ Speed Setting Increment : 10rpm
- ▶ Stirrer Plate Top : Stainless steel
- ▶ Base Diameter : 135 mm



Specifications :

- ▶ Dimension (mm) : 205 (W) X 335 (L) X 130 (H),
- ▶ Weight : 4.5Kg approx.
- ▶ Heater Power : 500W
- ▶ Power supply : 220~240 V AC, 50/60 Hz, 520 Watt

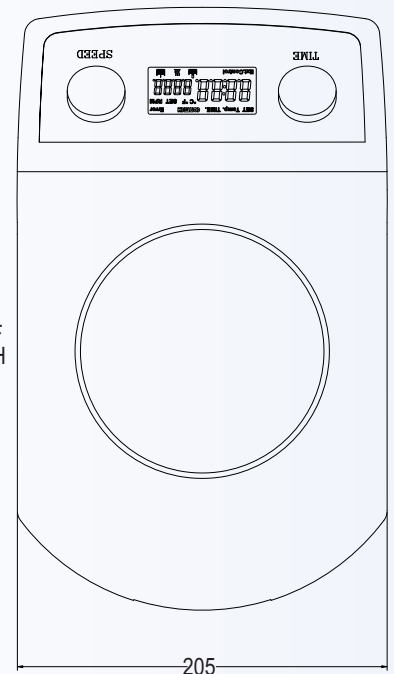
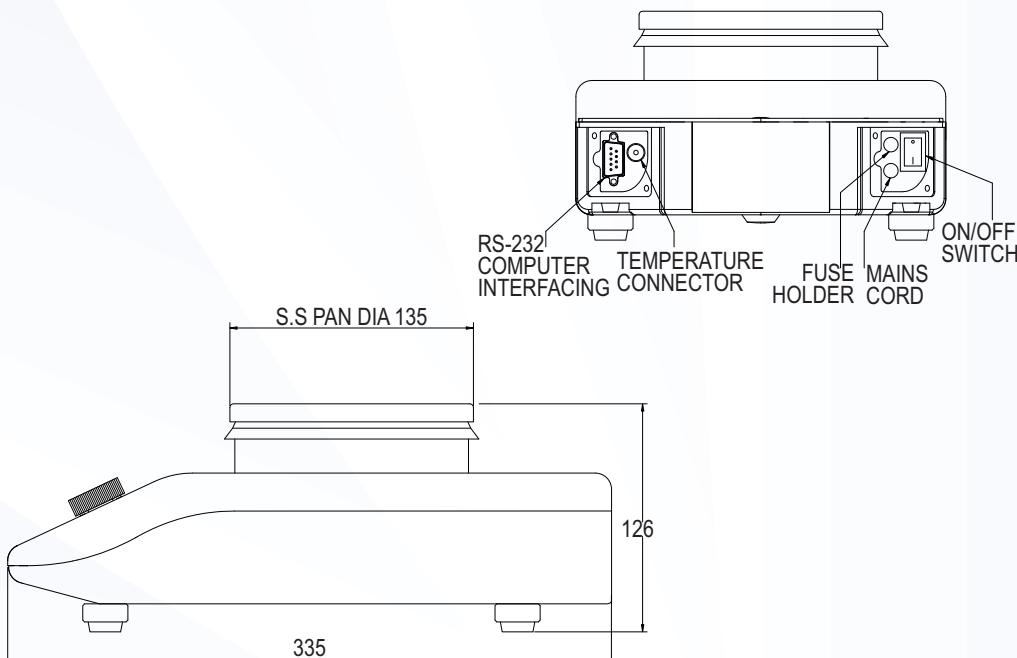

All Specifications and designs are subject to change for improvement.